

---

# PALBOARD®

Multilayered PVC Sheet

---

Fabrication Guide





**Content**

Cutting -----2  
Drilling -----3  
Milling\Routing -----3  
V-Groove-----3  
Thermal Expansion / Contraction -----4  
Screwing and Nailing -----4  
Installation-----4  
Tips on Sign Installations with Posts ----4  
Significant Items to be Considered -----4  
Hanging Signs -----4  
Adhesive Bonding of PALBOARD®-----5  
Heat Bending -----5  
Painting -----6  
Die Cutting / Texture Die Pressing -----6  
Graphic Applications -----7  
Direct Digital Printing-----7  
Laminating -----8  
Chemical Resistance-----9  
Recommended Uses and Restrictions-13  
Further Information-----13  
Physical Properties -----13  
PSDS Sheet -----13



PALBOARD is an innovative multilayered sheet that offers the qualities of rigid and foamed PVC together.

Based on Palram's 50 year experience in extruding quality PVC sheets, it combines the surface quality and characteristics of rigid PVC with a reduced weight due to a recycled foamed PVC core.

PALBOARD is easy to fabricate, making it ideal for a wide variety of sign and display applications. It makes an excellent printing substrate and is suitable for digital or traditional printing. PALBOARD can be used in harsh chemical environments due to its high chemical resistance.



Superior Print Surface



Chemical Resistant



Superior Strength



Lightweight



Easy to Fabricate



Premium Solution

## Cutting

### Bridge Saw

For best results use a 17.72" blade, 100 teeth. Recommended cutting speed is up to 10.668 m/min. (35 ft./min.)

### Circular Saws

PALBOARD material up to 3 mm thick can be cut with a knife or blade. For PALBOARD sheets 3 mm and thicker, carbide-tipped, High speed steel blades normally recommended for wood or plastic 10" x 72 tooth can be used.

The following settings are recommended:

- **Rake angle:** 0° - 8°
- **Clearance angle:** 10° - 15°
- **Cutting speed:** 4,000 - 8,000 RPM Feed rate: 6 - 30 meter per minute (19 - 98 ft per minute)
- **Tooth pitch:** 5 - 12 mm (0.197 - 0.472 inch)

### Band Saws

High speed steel blades normally recommended.

- **Teeth:** 180 tooth blade
- **Cutting speed:** 3,000 to 5,000 RPM
- **Feed rate:** 6 - 30 meter per minute (19 - 98 ft per minute)

### Jigsaw

Rough cut type blades ground for plastics can be used on PALBOARD sheets. Smooth metal-cutting blades are not recommended.

### Table Top Cutters / Vertical Cutters

It is recommend using vertical cutters with Twin Wheel Head blade which are used for cutting ACP (Aluminum Composite Panel).



## Drilling

PALBOARD can be drilled with carbide-tipped bits using twist drills recommended for metals.

The following settings are recommended:

- **Point angle:** between 90° - 110°
- **Spiral angle:** 30°
- **Cutting speed:** 1,000 - 3,000 RPM
- **Feed rate:** 0.2 - 0.5 mm/revolution

The minimum distance from the edge should be 2 times the hole diameter. In an effort to reduce heat buildup during drilling of thicker PALBOARD sheets, it may be necessary to periodically remove the drill bit from the PALBOARD material.

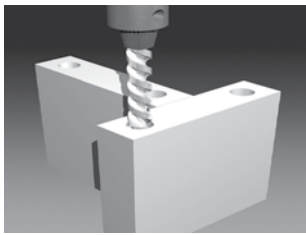

## Milling\Routing

PALBOARD can be milled by using standard milling machines of various types utilizing the following guidelines:

- **Relief angle:** 5° to 10°
- **Rake angle:** -10° to 0°
- **Cutting speed:** up to 18,000 RPM
- **Cutting feed:** 0.3-0.5 mm / revolution

PALBOARD material can be easily routed using multi-fluted carbide tools on standard woodworking routers. Standard tools and machines can be utilized with no need to alter equipment. Adjust feed and speed rates as needed to achieve the best edge finish on the PALBOARD parts.

For Milling\Cutting\Engraving it is recommend to use a Single Flute\Tooth 'UP Cut Bit' (Left Hand Bit). The recommend cutting diameter (d) is 4 mm (0.1575 in); the Length of cut (l) is 12 mm (0.472 in).

For the following Bit manufacturers the specified bit is:

- ZUND: 3910720
- ESKO: BIT-ADS06-4012-50
- VHF: ES-PS-0300-4-120-50
- CROWN-NORGE: S1-4.0/4-12-50 A
- ONSRUD: 63-750 SC 1F Upcut "O" Flute
- ONSRUD: 52-707 SC 2F Upcut "O" Flute

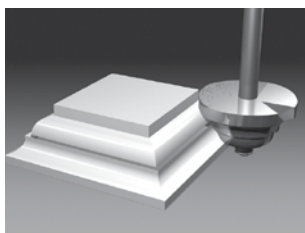

## V-Groove

For V Groove Milling\Routing, it is recommended to use a bit specified for bending applications. Such bits offer top angles of 90°, 120° or 135°.

### Application:

For bending applications use the 3, 5 & 10 mm PALBOARD sheets. The Bit with 90° produces rectangular bending with nearly no gaps. The 120° or 135° rounded tip bits produce acute angled bending of up to 90° with approx. 2 mm (0.079 inch) gap between the sides.

### Practical tip:

Please note: Leave a remainder of 0.6 mm to 0.8 mm (0.024 inch to 0.032 inch) of the PALBOARD which must not be milled.

For the following Bit manufactureres the specified bit is:

- ZUND: 90° - R141 (3910799)
- ESKO: 90° - BIT-EBV06-94 | 120° - BIT-EBV06-120-2F
- VHF: 45° - BIT- RB-AV-135-1800-6-59 [to remain 0.8 mm (0.032 inch) of lower layer] 90° - BIT- ES-AV-090-1000-180-6-50 [to remain 0.7 mm (0.0276 inch) of lower layer]
- ONSRUD: 37-52 Carbide 2F V Bottom

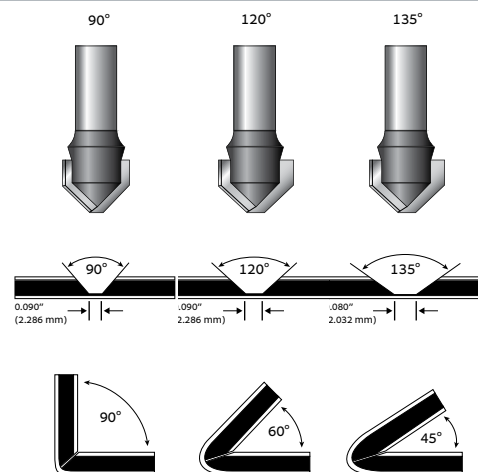



## Thermal Expansion / Contraction

As with most plastics, PALBOARD Multilayered PVC Sheet will expand and contract with an increase or reduction in temperature. This material property is known as linear thermal expansion and contraction.

Since PALBOARD can be used in a wide variety of indoor and outdoor applications, linear thermal expansion and contraction may need to be considered during the fabrication and installation of the material. It is important to take in to account the temperature at which the PALBOARD material was fabricated as well as the temperature of the installation.

PALBOARD should not be used in applications or climatic conditions that exceed 60°C(150°F) (ambient or surface temperature), at which temperature the PALBOARD will soften and permanently deform. Dark colors are generally not recommended for outdoor use, as they absorb heat and can easily exceed the maximum allowable temperature of 60°C (150°F).

| PALBOARD Linear Expansion / Contraction Quick Reference |  |      |      |      |
|---|--|------|------|------|
| Total Temp. Change [Δ]                                  | Expansion / Contraction of Material at Standard Lengths / Widths [in mm] |      |      |      |
|   | 1220   | 1500 | 2440 | 3050 |
| -7°C  | 0.9  | 1.1  | 1.8  | 2.3  |
| 4°C   | 1.8  | 2.3  | 3.6  | 4.5  |
| 15°C  | 2.2  | 3.4  | 5.4  | 6.7  |
| 27°C  | 3.6  | 4.5  | 7.2  | 9.0  |
| 38°C  | 4.5  | 5.6  | 9.0  | 11.2 |
| 49°C  | 5.4  | 6.7  | 10.8 | 13.5 |
| 66°C  | 6.3  | 7.9  | 12.6 | 15.8 |

## Screwing and Nailing

Any type of screw or nail can be used to fasten PALBOARD material. Power nailers and screw driving equipment are suggested. Inserting the screw or nail in an elongated slot or an oversized hole is recommended so that the material can expand or contract if fluctuations in temperature occur. For best results, use oversized washers or grommets in combination with screws.

## Installation

PALBOARD is manufactured as a Co-Extruded PVC product with a directional grain running the entire length of the sheet. This manufacturing process gives PALBOARD greater flexural strength in the direction of the extrusion. The grain of the PALBOARD should always be installed perpendicular to the fastening point.

## Tips on Sign Installations with Posts

The following tips have been compiled to be used as a general guide for fixing PALBOARD for a minimum amount of breakage. Unusual designs falling outside the examples given may require certain modifications when considering PALBOARD.

## Significant Items to be Considered

1. Bolt holes should always be larger than the bolt shaft to allow for thermal expansion and contraction, thus eliminating the possible stress at bolt fixing points. The use of washers spreads the compressive load when bolts/nuts are tightened. Be sure not to over tighten as this will weaken the connection.
2. Split timber posts are the best to use because the PALBOARD is supported evenly on both sides. If steel or aluminum poles are used, nylon bolts and washers give the best results. Be certain to use an adequate number of fasteners for these types of installation. They should be evenly spaced from the top and bottom edges.

## Hanging Signs

PALBOARD may be successfully used as interior hanging signs. As PALBOARD is an Co-Extruded sheet product, thin gauges or large hanging signs may require additional support. The addition of an aluminum or thick a walled plastic "C" channel across the top, bottom, or around the perimeter may be needed to alleviate any tendencies to warp. When the additions of supporting channels are not an option, the method illustrated below may also be used to help prevent bending. Holes should be located 2-1/2 times material thickness from edge.

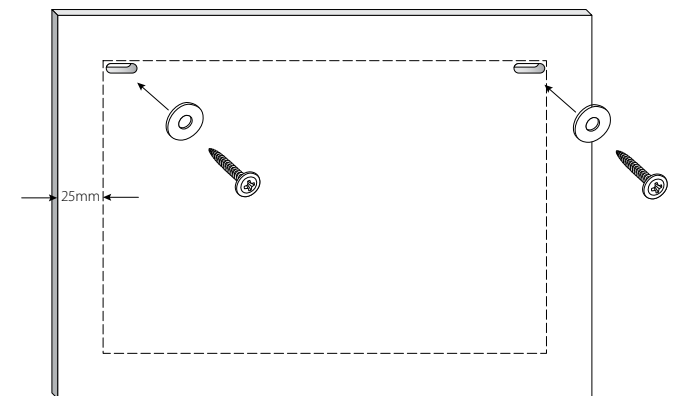



## Adhesive Bonding of PALBOARD®

### General Information

PALBOARD material can readily be bonded to itself or other materials. Commercially available adhesives that are suitable for bonding rigid PVC materials can be used for this purpose

### There are several considerations when choosing an adhesive:

- The material to be bonded with PALBOARD
- Strength required—structural vs. non-structural
- Temperature range expected
- Expansion/contraction
- Ease of application methods, curing times
- Cost effectiveness
- Environmental and safety considerations—flammability, fumes, odors, etc.

### Surface Preparation

In order to attain the optimum bond, the PALBOARD material surfaces to be bonded must be cleaned and degreased using a white cloth soaked in isopropyl alcohol to insure good adhesion.

### Selection of Adhesives

The selection of the proper adhesive for a project depends on the materials to be joined, as well as the end use and other considerations mentioned previously. The following suggestions serve as general guidelines:

#### Bonding PALBOARD to PALBOARD Material

- For edge bonding and joining parts made of PALBOARD material, use a PVC solvent such as (THF, MEK, cyclohexanone solvent systems).
- VHB 5952 is the recommended VHB tape for PVC, Scotch Weld DP810 which is a two part low odor acrylic adhesive also bonds very well to PVC.
- For bonding large areas: If using PVC solvent such as pipe cement, spread with notched trowel and work rapidly.

#### Bonding PALBOARD to Non-Porous Solid Material (such as PVC, other plastics or metal):

Contact adhesive with solvent:

- Neoprene, nitrile, polyurethane or other synthetic rubber types.
- Adhesive must be applied to both faces. Parallel beads of adhesive are often preferred because it allows evaporation of solvent providing faster cure.
- Use a slow setting adhesive, when bonding large areas. This allows for more time to properly install the panels prior to the adhesive curing.
- For bonding PALBOARD material to flexible PVC sheets, only plasticizer-resistant types of adhesives should be used.

#### Bonding PALBOARD to Porous Materials (such as paper, textiles, fabrics or wood).

- Contact adhesive with solvent: Same systems as for non-porous materials.
- Construction mastic, structural silicone adhesives.
- Expected temperature ranges (expansion/contraction), substrate and size of PALBOARD material panels should be taken into consideration when deciding on a method of attachment.

### Heat Bending

PALBOARD sheet material can be bent by using Calrod or other, radiant heaters, strip heaters or air-circulated ovens. Heat guns can also be used on small areas. To ensure best results, a rheostat should be used to control heating of the PALBOARD so that the surface temperature does not exceed 165°C(329°F). Heating PALBOARD material over 165°C(329°F) can cause the surface to become rough and possibly discolor.

When using a metal contact strip heater, cover the heater strip with Teflon spray to prevent marking the PALBOARD. Different sizes of rectangular heating bars can be used to produce bends of different radii. The larger the heated area of the PALBOARD, the larger the radius that can be created. PALBOARD should be heated from both sides when the sheet is thicker than 4 mm. PALBOARD requires heating at the rate of approximately 30 to 40 seconds per millimeter of thickness prior to bending.

To form tighter bends with smaller radii, use a small heated area on the upper surface (inside the bend) of the PALBOARD sheet and a larger heated area on the bottom surface (on the outside of the bend) of the sheet. A minimum radius of twice the sheet thickness is necessary to avoid breakage. When bending PALBOARD into an angle, typically the extension of the PALBOARD on either side of the angle should be at least 20 times the thickness of the PALBOARD material.

For example, 6 mm PALBOARD would require the extension on each side to be 120 mm in order to avoid warping of the material. For sides less than 20 times the material's thickness, the entire sheet must be heated. Once the PALBOARD is bent, place it in a fixture, such as a jig or clamp, to cool. Fans and/or compressed air will speed the cooling process.



## Painting

The painting of PALBOARD is easily accomplished with paints known to have compatibility with rigid PVC.

Selection of a paint system for each use should be guided by the following:

### Types of paints known compatible with PALBOARD® sheet

- Vinyls
- Acrylic Lacquers
- Two part polyurethanes

With PALBOARD, water-based latex systems and oil-based enamels generally do not have the good adherence properties of solvent based systems. Although, the use of primers can improve the adherence of non-solvent based systems, the adherence is usually minimal.

### Surface Preparation

- The surface to be painted must remain dry, clean, and grease free.
- Any surface scratches on PALBOARD will have a tendency to telegraph through the paint. In order to remove small scratches or dents, rapidly fan a heat gun over the affected area. Care must be taken not to leave the hot air in one place for too long, as the surface can be deform.
- It is highly recommended that the surface be cleaned with a rag moistened with isopropyl alcohol prior to painting.

### Adhesion Test - 'Cross-cut' Test

The paint system chosen should always be tested for adequate adhesion. To test for adhesion, conduct the Cross Hatch Test after the paint has dried for at least 24 hours.

- Make eleven parallel cuts 1/16" apart with a razor blade knife. Make eleven similar cuts at 90 degrees to cross the first set.
- Across the scored area apply a strip of strong tape, such as #610 Scotch tape. Press firmly.
- Immediately remove the tape by pulling it back upon itself at 180 degrees in one rapid motion.
- There shall be no removal of the paint squares to obtain a good adhesion rating.

### Application

- Paints can usually be applied with a brush or roller, although conventional air spray equipment will provide a more consistent appearance.
- Consult paint manufacturer's literature for recommended application technique and thinning requirements.

### Drying

PALBOARD is a thermoplastic material. It should not be dried at temperatures in excess of 150°F. For drying and cure times, consult paint manufacturer's literature.

**CAUTION: Due to the wide variety of paint products on the market, and the fact that some paints have been known to embrittle or bow PALBOARD, testing is recommended for the initial use of any coating system before commercialization.**

## Die Cutting / Texture Die Pressing

PALBOARD sheets can be die-cut and pressed with a flat bed press, either a moving-platen press or a clamshell press.

PALBOARD flat shapes or cutouts can be rapidly produced using steel rule die cutting.

A texture die press is an efficient method for stamping designed surface patterns onto PALBOARD. PALBOARD absorbs pressure and retains die-pressed shapes.

### General notes

- Cutting and texture pressing can be done on the same die plate.
- Prior to die cutting or texture die pressing, PALBOARD sheets can be printed, painted, or laminated/hot stamped.
- To reduce the likelihood of fracturing, it is recommended to heat the PALBOARD sheets to at least 20°C/68°F prior to the die process.
- Following die cutting/pressing, the pieces may be heat bent, fastened, glued, routed, or machined.

### Die Cutting

- A sharp steel rule blade should be used on a die plate.
- Make sure the rule has the correct gauge and bevel.
- Align the press bed so that the steel rule cuts evenly through the PALBOARD sheets.
- Use a die with ejection and stripping rubber/foam. During the press opening, stripping prevents cracking and helps eject the part from the die.
- With thicker-gauge PALBOARD, die cut quality may be reduced. Die cutting PALBOARD sheets beyond 5 mm gauge increases the risk of deformation or fracture.

### Texture Plates Die Pressing

- Presses should be aligned to go no deeper than 1.5mm into PALBOARD.
- Die texture press plates should be made of harder material than PALBOARD.



## Graphic Applications

PALBOARD performs superbly in a wide range of graphic applications including those involving paints, screen printing, digital wide format printing and vinyl films. PALBOARD can be used to create weather-resistant signs, displays or Point of Purchase (POP) materials.

The smooth PALBOARD surface is ideal for all types of graphics, and it does not require surface preparation or surface treatment.

### Screen Printing

With PALBOARD, the process of Screen Printing is easily accomplished. The surface of PALBOARD has a closed cell semi-matte finish that makes mistakes easily wipe off with the appropriate thinner. The use of Vinyl and Vinyl/acrylic, solvent based inks are very compatible with PALBOARD.

The use of Water Based Screen Printing Inks has also had some success with PALBOARD material. Ink manufacturer directions must be followed for good adhesion. Surface preparation of PALBOARD for screen printing is similar to those of painting.

- The surface to be screen printed area must remain dry, clean, and grease free.
- Any surface scratches on the PALBOARD will have a tendency to show through the ink.

In order to remove small scratches or dents, rapidly fan a heat gun over the affected area. Care must be taken not to leave the hot air in one place for too long, as the surface can become deformed. It is highly recommended that the surface be cleaned with a white cloth moistened with isopropyl alcohol prior to printing.

All screen printing inks should be tested in a manner which duplicates your printing process before initiating production. It is strongly recommended to consult the appropriate ink manufacturer regarding any required ink additives such as catalyst for proper adhesion and exterior usage. Screen Printing ink should air dry, rather than be heat dried. Temperatures in excess of 150°F may cause warping or bending of PALBOARD material.

Most UV Screen Printing Inks that are compatible with rigid PVC will work on PALBOARD. The most important factor to be considered when using UV systems is the curing oven. Low wattage bulbs should be used to keep the temperature below 150°F. The use of UV curing systems, which have variable speed conveyors, are considered the best type to use with PALBOARD.

## Direct Digital Printing

Wide format and flatbed printers use various ink and ink curing technologies to allow high quality printing at relatively high speeds.

High quality digital printing depends on various factors:

- Printer capabilities
- Ink technology and quality
- Type of printing substrate and quality
- Machine operator

PALBOARD'S bright whiteness enables printers to print directly on it and achieve accurate, consistent color values and brightness.

The PALBOARD is suitable for use with UV\UV-Led curing and solvent-based digital inks, and for IR drying when water-based inks are used.

PALBOARD retains superb whiteness, even after intense UV curing.

### Protective Film Masking

The protective polyethylene film mask helps prevent surface abrasion and stains. However, removing the protective film may cause an increase of static electric charge, which can affect ink coverage. Therefore, after peeling the film away from the sheet, the static electricity that has built up in the sheet should be discharged using an ionized gun or a suitable device provided by the printer manufacturer.

### Ink

PALBOARD is suitable for all types of inks: Aqueous, Solvent-Based, and UV\UV-Led curable. In fact, PALBOARD has been tested and approved by major printer OEM's around the world, including AGFA, Efi, HP, Mutoh, Canon, and more. Consult the printer manual or contact the printer manufacturer for recommendations and compatibility information.

### Drying the ink

The two main drying technologies are:

IR (Infrared) – Long exposure to high temperature in the drying tunnel may cause distortions in the sheet.

UV (Ultraviolet) – UV\UV-Led levels must be adjusted according to the printing speed and substrate. UV overexposure can cause discoloration of both the ink and substrate.

### Print Head Adjustment

The distance between the print head and the substrate can have a significant effect on print quality. Manufacturer specifications, combined with operator experience, should determine print head distance from the substrate.

The suggested starting distance should not be more than 1.5 mm from the print head to the substrate.



## Laminating

PALBOARD is an ideal material for applications that require lamination. This section provides preparation information processes as well as detailed instructions for the various types of lamination that can be used with PALBOARD. Because prints are one of the most frequently laminated materials, the sections that follow will generally refer to the lamination of a print, although many other materials can be used.

**Please Note!** Since PALBOARD material may warp when heated above 150°F or when heated from one side only, it cannot be used in any lamination process requiring heat.

### Adhesion

For best results, the PALBOARD material should be cleaned with isopropyl alcohol prior to adhesion and allowed to dry thoroughly. When laminating with pressure-sensitive adhesives, a force of 25–40 psi is required. Proper spacers are also critical. Because force must be applied equally across the material, the top roll must move evenly from left to right while maintaining even contact between top and bottom laminating rolls. To achieve even contact, “zero the nip,” then use spacer shims to preset the nip opening for a particular laminate. Use sufficient pressure to completely eliminate any air bubbles between the PALBOARD material, the adhesive and the print or other material.

The lamination will achieve maximum bonding in three hours. If the lamination has been performed properly, the finished mount can be flexed without the print becoming loose in the center. To prevent moisture from becoming trapped between layers of porous material (such as paper) and creating blisters, the level of moisture in both the material to be laminated and the atmosphere should be reduced before pressing. Some materials may require pre-drying. PALBOARD is nonporous and does not need pre-drying.

### Preventing Surface flaws

Surface blemishes, such as wrinkles, can be caused by misalignment of the adhesive roll or too much pressure or rollers that are not parallel. Trapped dirt or lumps of hardened adhesive common with glossy prints may create small bumps in the finished product. In order to prevent these problems, equipment used for PALBOARD lamination must be kept clean. Use a fresh roll or sheet of transfer adhesive if bumps are caused by hardened adhesive. Dirt problems can be minimized by using an ionizing static eliminator. Using prints or other materials made with a paper 0.007” or thicker can help prevent strike through. For best results, wipe down the back of the print and the face of the PALBOARD mount with a clean, dry cloth before it passes through the roll nip. Whether the finished product is to be used indoors or outdoors, a clear, high gloss overlay will help protect against fading as well as enhance the color.

## Laminating Techniques

Four techniques are recommended for laminating materials to PALBOARD, as described in the following sections. Depending upon the type of applications and the equipment available, one or more of these processes may be appropriate for a particular application. None of these processes involves the use of heat. Because PALBOARD may warp at temperatures above 150°F or when heated from one side only, it cannot be dry mounted or hot mounted.

The four recommended lamination techniques for PALBOARD are:

- Cold laminating with a press using adhesive-backed paper
- Cold laminating using a vacuum press
- Hand laminating using transfer adhesive
- Hand laminating using spray adhesive

### Cold Laminating with a Press using Adhesive-backed Paper

This process is most frequently used by commercial photo labs. Either of two types of liner films, a single release liner film or a double release liner film, can be used for this process. The basic process for laminating with a press using adhesive-backed paper is described in the following section.

- Set the roller pressure properly for the thickness of the pre-coated mounting substrate.
- Place the mounting substrate on a flat surface and expose approximately one inch of the adhesive by peeling back the release paper. Fold back the release paper, making an even crease across the paper.
- Carefully position the print on top of the substrate, using the folded release paper to prevent contact with the exposed adhesive. Once positioned correctly, carefully apply the print to the exposed adhesive, pressing from the center toward the edges to ensure a smooth tack.
- Place the direction switch in the forward position and the speed control on medium.
- Insert the materials to be processed into the laminator opening. Feed the substrate between the rollers until the pressure roller rests on the tacked portion of the material.
- Hold the un-tacked portion of the print up and against the pressure roller. Feed the substrate through the rollers while peeling the release paper off the mounting substrate with one hand. To prevent wrinkles, the print must be held against the roller with the opposite hand while the substrate feeds through the press.
- Remove the mounted print from the rear of the laminator and trim it to the required size.



### Coating using Single Release Liner Films

- Set the pressure properly for the thickness of the substrate(s) to be processed.
- Load the supply roll of pressure-sensitive adhesive.
- Pull approximately 12 inches of adhesive film forward off the roll. Rest the film, adhesive side up, on top of the pressure roller.
- Create a leader board by cutting a piece of substrate slightly larger than the width of the adhesive film and approximately four to six inches long. Lay the leader board across the adhesive film and smoothly adhere the bottom of the leader to the adhesive.
- Place the direction switch in the forward position and the speed control on medium.
- Pull the leader down and push it between the rollers. Feed the leader between the rollers approximately three to four inches. Be sure that the adhesive stays firmly adhered to the leader.
- Once this process has been completed (referred to as “stringing the web”) and the adhesive is feeding without wrinkles, the laminator is ready for production.
- To coat, feed a substrate behind the leader board and between the roller while depressing the foot switch. Feed until the substrate exits the rollers and automatically stops feeding. At this time, another substrate may be fed between the rollers for coating. This process is suitable for films with a paper release liner and leaves a 3/8” to 1/2” gap between the coated substrates to facilitate the trimming process.
- After exiting the laminator, the coated substrates should be split apart and trimmed.

### Coating using Double Release Liner Films

Coating with double release liner film, requires the use of a take-up mechanism to automatically remove and rewind one of the release liners during the coating procedure.

- Set the pressure properly for the thickness of the substrates to be processed.
- Load the supply roll of pressure-sensitive adhesive.
- Adhere double-stick tape or a pressure-sensitive adhesive film, to the surface of the take-up shaft.
- Pull approximately 18 inches of adhesive film forward off the roll and adhere one release liner side smoothly to the take-up shaft, taking care to ensure that the film is square with the supply roll and no diagonal wrinkles are apparent.
- Separate the adhesive film from the release liner secured to the take-up shaft and pull the adhesive film and remaining release liner down so that it rests adhesive side up on top of the pressure roller.
- Lay a leader board the same thickness as the substrates to be used across the exposed adhesive.

### Chemical Resistance

The mechanism of chemical attack on thermoplastics in general, and Palram PVC sheets in particular, differs significantly from the mechanism of corrosion of metals. Corrosion of metals results in a gradual loss of surface material as a result of electrolytic action by the relevant chemicals. Chemical attack on Palram PVC sheets, where it occurs, consists generally of absorption of the chemical by the PVC sheet and its subsequent swelling. The chemical resistance behavior of Palram PVC sheets is therefore simple to determine. The chemical resistance is expressed in terms of weight change (usually an increase) and volume change.

The table that appears in the following pages lists the resistance of Palram PVC sheets to a number of commonly encountered chemicals and other corrosive media at room temperature. (Information on chemical resistance at higher temperatures will be supplied upon request.) Where the chemical resistance varies with concentration, the results of tests at different concentrations is presented. The information listed is based on long-term laboratory tests and actual service installations. For chemicals and corrosive media not listed in the list, please contact your Palram representative. He will place you in contact with the Palram Technical Support Department. It is important to note that Palram PVC sheets are generally not recommended for use with acetone, ketones, ethers, and aromatic and chlorinated hydrocarbons.

The information on chemical resistance is based on our research and experience. It serves as a basis for recommendation.

Palram does not guarantee chemical resistance, unless specific tests are carried and separate documentation is supplied.



The table on the following page uses the following key:

|             |  |  |
|-------------|--|--|
| R Resistant | LR Limited Resistance (gradual attack over time may occur) | N Not Resistant (rapid attack or attack over short time period will occur) |
|-------------|--|--|

\*Concentration for aqueous solution except where noted

**IMPORTANT NOTE: The most up-to-date version of the information below is available on [www.palram.com](http://www.palram.com)**

| Chemical                             | Concentration %* | Resistance |
|--------------------------------------|------------------|------------|
| Acetaldehyde                         | 100              | N          |
| Acetic Acid                          | 80               | R          |
| Acetic Acid                          | 100              | LR         |
| Acetic Anhydride                     |                  | N          |
| Acetone                              |                  | N          |
| Acrylonitrile                        |                  | N          |
| Acetylene                            |                  | R          |
| Ajax                                 |                  | R          |
| Allyl Alcohol                        |                  | LR         |
| Aluminum Chloride                    | Saturated        | R          |
| Aluminum Fluoride                    |                  | R          |
| Aluminum Hydroxide                   |                  | R          |
| Aluminum Sulfate                     | Saturated        | R          |
| Ammonia (Gas)                        |                  | R          |
| Ammonia (Liquid)                     |                  | N          |
| Ammonium Acetate                     |                  | R          |
| Ammonium Bifluoride                  |                  | R          |
| Ammonium Bisulfate                   |                  | R          |
| Ammonium Chloride                    |                  | R          |
| Ammonium Fluoride                    | 25               | LR         |
| Ammonium Hydroxide                   | 28               | R          |
| Ammonium Nitrate                     |                  | R          |
| Ammonium Sulfate                     | Saturated        | R          |
| Ammonium Sulfide                     | Saturated        | R          |
| Amyl Acetate                         |                  | N          |
| Amyl Alcohol                         | Pure             | LR         |
| Aniline                              |                  | N          |
| Antimony Trichloride                 |                  | R          |
| Aqua Regia (3 parts HCl:1 part HNO3) |                  | N          |
| Arsenic Acid                         | 80               | R          |
| Barium Chloride                      |                  | R          |
| Barium Hydroxide                     |                  | R          |
| Barium Sulfate                       |                  | R          |
| Barium Sulfide                       |                  | R          |
| Beer                                 |                  | R          |
| Beet (Sugar Liquor)                  |                  | R          |
| Benzaldehyde                         |                  | LR         |
| Benzene                              |                  | N          |
| Benzoic Acid                         |                  | R          |
| Benzyl Alcohol                       |                  | R          |
| Bleach                               | 12% Chlorine     | R          |
| Boric Acid                           |                  | R          |
| Brake Fluid                          |                  | LR         |
| Brine                                |                  | R          |
| Bromic Acid                          |                  | R          |
| Bromine (Liquid)                     |                  | N          |
| Bromine (Water)                      |                  | LR         |
| Bromine (Vapor)                      | 25               | R          |

| Chemical                             | Concentration %* | Resistance |
|--------------------------------------|------------------|------------|
| Bromobenzene                         |                  | N          |
| Butadiene                            |                  | N          |
| Butane                               |                  | N          |
| Butyl Acetate                        |                  | N          |
| Butyl Alcohol                        |                  | R          |
| Butyl Stearate                       |                  | R          |
| Butyric Acid                         |                  | N          |
| Calcium Chloride                     | Saturated        | R          |
| Calcium Hydroxide                    |                  | R          |
| Calcium Hypochlorite                 |                  | R          |
| Calcium Nitrate                      |                  | R          |
| Calcium Sulfate                      |                  | R          |
| Camphor                              |                  | R          |
| Carbon Dioxide Gas (Moist)           |                  | R          |
| Carbon Disulfide                     |                  | N          |
| Carbon Monoxide                      |                  | R          |
| Carbon Tetrachloride                 |                  | N          |
| Castor Oil                           |                  | R          |
| Caustic Potash (Potassium Hydroxide) | 50               | R          |
| Caustic Soda (Sodium Hydroxide)      | 50               | R          |
| Chlorine Dioxide                     | 15               | R          |
| Chlorine Gas (Dry)                   |                  | N          |
| Chlorine Gas (Wet)                   |                  | N          |
| Chlorine Water                       | 2                | R          |
| Chloroacetic Acid                    |                  | R          |
| Chlorobenzene                        |                  | N          |
| Chloroform                           |                  | N          |
| Chrome Alum                          | Saturated        | R          |
| Chromic Acid                         | 10               | R          |
| Citric Acid                          | Saturated        | R          |
| Copper Fluoride                      |                  | R          |
| Copper Nitrate                       |                  | R          |
| Copper Sulfate                       |                  | R          |
| Corn Syrup                           |                  | R          |
| Cottonseed Oil                       |                  | R          |
| Cresol                               |                  | N          |
| Cresylic Acid                        | 50               | R          |
| Cupric Chloride                      | Saturated        | R          |
| Cuprous Chloride                     | Saturated        | R          |
| Cyclohexane                          |                  | N          |
| Cyclohexanol                         |                  | N          |
| Cyclohexanone                        |                  | N          |
| Dextrose                             |                  | R          |
| Detergent (most)                     |                  | R          |
| Diesel Fuel                          |                  | R          |
| Diethyl Ether (Ethyl Ether)          |                  | R          |
| Dimethyl Amine                       |                  | N          |
| Diethyl Phthalate                    |                  | N          |



The table on the following page uses the following key:

|             |  |  |
|-------------|--|--|
| R Resistant | LR Limited Resistance (gradual attack over time may occur) | N Not Resistant (rapid attack or attack over short time period will occur) |
|-------------|--|--|

\*Concentration for aqueous solution except where noted

**IMPORTANT NOTE: The most up-to-date version of the information below is available on [www.palram.com](http://www.palram.com)**

| Chemical                          | Concentration %* | Resistance |
|-----------------------------------|------------------|------------|
| Dioxane                           |                  | N          |
| Ethanol (Ethyl Alcohol) and Water | All              | R          |
| Ethanol (Ethyl Alcohol)           | Pure             | R          |
| Ethyl Acetate                     |                  | N          |
| Ethyl Chloride                    |                  | N          |
| Ethylene Chlorohydrin             |                  | N          |
| Ethylene Dichloride               |                  | N          |
| Ethylene Glycol                   |                  | R          |
| Fatty Acids                       |                  | R          |
| Ferric Acetate                    |                  | R          |
| Ferric Chloride                   | Saturated        | R          |
| Ferric Hydroxide                  |                  | R          |
| Ferric Nitrate                    |                  | R          |
| Ferric Sulfate                    |                  | R          |
| Ferrous Chloride                  |                  | R          |
| Ferrous Hydroxide                 |                  | R          |
| Ferrous Sulfate                   |                  | R          |
| Fluorine Gas                      |                  | LR         |
| Fluorine Gas (wet)                |                  | R          |
| Fluoroboric Acid                  |                  | R          |
| Formaldehyde                      |                  | LR         |
| Formic Acid                       |                  | R          |
| Freon 11, 12, 113, 114            |                  | LR         |
| Fluosilicic Acid                  |                  | R          |
| Fruit Juices and Pulp             |                  | R          |
| Gasoline                          |                  | R          |
| Glucose                           |                  | R          |
| Glycerine                         |                  | R          |
| Heptane                           |                  | R          |
| Hexane                            |                  | N          |
| Hydrazine                         |                  | N          |
| Hydrobromic Acid                  | 20               | R          |
| Hydrochloric Acid                 | 35               | R          |
| Hydrofluoric Acid                 | 70               | LR         |
| Hydrogen                          |                  | R          |
| Hydrogen Peroxide                 | 50               | R          |
| Hydrogen Sulfide                  |                  | R          |
| Iodine                            |                  | N          |
| Kerosene                          |                  | R          |
| Ketones                           |                  | N          |
| Lactic Acid                       | 20               | R          |
| Laurel Chloride                   |                  | R          |
| Lead Acetate                      |                  | R          |
| Lead Chloride                     |                  | R          |
| Lead Nitrate                      |                  | R          |
| Lead Sulfate                      |                  | R          |
| Linoleic Acid                     |                  | R          |
| Linoleic Oil                      |                  | R          |

| Chemical                  | Concentration %* | Resistance |
|---------------------------|------------------|------------|
| Linseed Oil               |                  | R          |
| Lithium Bromide           |                  | R          |
| Lubricating Oil           |                  | R          |
| Magnesium Carbonate       |                  | R          |
| Magnesium Chloride        |                  | R          |
| Magnesium Hydroxide       |                  | R          |
| Magnesium Sulfate         |                  | R          |
| Maleic Acid               |                  | R          |
| Malic Acid                |                  | R          |
| Manganese Chloride        |                  | R          |
| Manganese Sulfate         |                  | R          |
| Mercuric Chloride         |                  | R          |
| Mercuric Nitrate          |                  | R          |
| Mercuric Sulfate          |                  | R          |
| Mercury                   |                  | R          |
| Methanol and Water        | All              | R          |
| Methanol (Methyl Alcohol) | Pure             | R          |
| Methyl Chloride           |                  | N          |
| Methyl Ethyl Ketone (MEK) |                  | N          |
| Methylmethacrylate        |                  | R          |
| Methyl Sulfate            |                  | LR         |
| Methyl Sulfuric Acid      |                  | R          |
| Methylamine               |                  | N          |
| Methylene Bromide         |                  | N          |
| Methylene Chloride        |                  | N          |
| Methylene Chlorobromate   |                  | N          |
| Methylene Iodide          |                  | N          |
| Milk                      |                  | R          |
| Mineral Oil               |                  | R          |
| Motor Oil                 |                  | R          |
| Naphtha                   |                  | R          |
| Naphthalene               |                  | N          |
| Nickel Chloride           |                  | R          |
| Nickel Nitrate            |                  | R          |
| Nickel Sulfate            |                  | R          |
| Nitric Acid               | 60               | R          |
| Nitrobenzene              |                  | N          |
| Nitroglycerine            |                  | N          |
| Nitrous Oxide             | Saturated        | R          |
| Oleic Acid                |                  | R          |
| Oxalic Acid               |                  | R          |
| Oxygen                    |                  | R          |
| Ozone                     |                  | R          |
| Palmitic Acid             | 40               | R          |
| Paracetic Acid            | 70               | LR         |
| Perchloric Acid           |                  | LR         |
| Phenol                    | 85               | N          |
| Phosphoric Acid           |                  | R          |



The table on the following page uses the following key:

|             |  |  |
|-------------|--|--|
| R Resistant | LR Limited Resistance (gradual attack over time may occur) | N Not Resistant (rapid attack or attack over short time period will occur) |
|-------------|--|--|

\*Concentration for aqueous solution except where noted

**IMPORTANT NOTE: The most up-to-date version of the information below is available on [www.palram.com](http://www.palram.com)**

| Chemical                   | Concentration %* | Resistance |
|----------------------------|------------------|------------|
| Phosphorous (Yellow)       |                  | R          |
| Phosphorous Pentoxide      |                  | R          |
| Phosphorous Trichloride    |                  | N          |
| Photographic Chemicals     |                  | R          |
| Picric Acid                |                  | N          |
| Plating Solutions          |                  | R          |
| Potassium Bichromate       |                  | R          |
| Potassium Bromate          |                  | R          |
| Potassium Bromide          | Saturated        | R          |
| Potassium Chloride         |                  | R          |
| Potassium Chlorate         |                  | R          |
| Potassium Chromate         |                  | R          |
| Potassium Cyanide          |                  | R          |
| Potassium Dichromate       |                  | R          |
| Potassium Ferricyanide     |                  | R          |
| Potassium Fluoride         |                  | R          |
| Potassium Hydroxide        | 50               | R          |
| Potassium Nitrate          |                  | R          |
| Potassium Perborate        |                  | R          |
| Potassium Perchlorate      |                  | R          |
| Potassium Permanganate     | 10               | R          |
| Potassium Persulfate       |                  | R          |
| Potassium Sulfate          |                  | R          |
| Propane                    |                  | R          |
| Propyl Alcohol (1Propanol) | 100              | R          |
| Propylene Dichloride       |                  | N          |
| Propylene Oxide            |                  | N          |
| Pyridene                   |                  | N          |
| Pyrogallic Acid            |                  | R          |
| Salad Oil                  |                  | R          |
| Salicylic Acid             |                  | R          |
| Selenic Acid               |                  | R          |
| Silicic Acid               |                  | R          |
| Silver Cyanide             |                  | R          |
| Silver Nitrate             |                  | R          |
| Silver Sulfate             |                  | R          |
| Sodium Acetate             |                  | R          |
| Sodium Benzoate            |                  | R          |
| Sodium Bicarbonate         |                  | R          |
| Sodium Bichromate          |                  | R          |
| Sodium Bisulfate           |                  | R          |
| Sodium Bisulfite           |                  | R          |
| Sodium Carbonate           |                  | R          |
| Sodium Chlorate            |                  | R          |
| Sodium Chloride            |                  | R          |
| Sodium Chlorite            |                  | N          |
| Sodium Cyanide             |                  | R          |
| Sodium Dichromate          |                  | R          |

| Chemical                     | Concentration %* | Resistance |
|------------------------------|------------------|------------|
| Sodium Ferricyanide          |                  | R          |
| Sodium Ferrocyanide          |                  | R          |
| Sodium Fluoride              |                  | R          |
| Sodium Hydroxide             | 50%              | R          |
| Sodium Hypochlorite          | 16% Chlorine     | R          |
| Sodium Nitrate               |                  | R          |
| Sodium Nitrite               |                  | R          |
| Sodium Perchlorate           |                  | R          |
| Sodium Peroxide              |                  | R          |
| Sodium Sulfate               |                  | R          |
| Sodium Sulfide               |                  | R          |
| Sodium Sulfite               |                  | R          |
| Sodium Thiosulfate           |                  | R          |
| Stannic Chloride             |                  | R          |
| Stannous Chloride            |                  | R          |
| Stearic Acid                 |                  | R          |
| Succinic Acid                |                  | R          |
| Sugar                        | Saturated        | R          |
| Sulfur Dioxide (Dry Gas)     |                  | R          |
| Sulfuric Acid                |                  | R (LR)     |
| Sulfurous Acid               | <80 (>80)        | R          |
| Tannic Acid                  |                  | R          |
| Tanning Liquors              |                  | R          |
| Tartaric Acid                |                  | R          |
| Tetraethyl Lead              |                  | R          |
| Tetrahydrofuran              |                  | N          |
| Tetrasodium Pyrophosphate    |                  | R          |
| Thionyl Chloride             |                  | N          |
| Titanium Tetrachloride       |                  | R          |
| Toluene                      |                  | N          |
| Trichloroacetic Acid         |                  | R          |
| Trichloroethylene            |                  | N          |
| Triethanolamine              |                  | R          |
| Triethylamine                |                  | N          |
| Trimethylamine               |                  | LR         |
| Trisodium Phosphate          |                  | R          |
| Tuepentine                   |                  | LR         |
| Urea                         |                  | R          |
| Vasilene                     |                  | N          |
| Vegetable Oils               |                  | R          |
| Vinegar                      |                  | R          |
| Vinyl Acetate                |                  | N          |
| Water (Demineralized or Sea) |                  | R          |
| Wine or Whiskey              |                  | R          |
| Xylene                       |                  | N          |
| Zinc Chloride                |                  | R          |
| Zinc Nitrate                 |                  | R          |
| Zinc Sulfate                 |                  | R          |



## Recommended Uses and Restrictions

Please consult the relevant product and/or application information for this product within this guide, or in other related sales literature.

## Further Information

Additional information on this product may be obtained by calling your Palram Sales or Customer Service Contact.

## Physical Properties

| Property                                | Standard    | Conditions     | Units                | Value                |
|---|-------------|----------------|----------------------|----------------------|
| <b>Physical</b>                         |             |                |                      |                      |
| Density                                 | ASTM D-792  |                | g/cm <sup>3</sup>    | 0.58 - 0.62          |
| Water absorption                        | ASTM D-570  | 24 hr @ 23°C   | %                    | 3mm - 0.5            |
| <b>Mechanical – Machine direction</b>   |             |                |                      | 5mm - 0.8            |
| Flexural modulus                        | ASTM D-790  |                | MPa                  | 1600                 |
| Shore hardness                          | ASTM D-2240 |                | Shore D              | 50                   |
| <b>Thermal</b>                          |             |                |                      |                      |
| Service temperature range               |             |                | °C                   | -10 to 55            |
| Heat deflection temperature             | ASTM D-648  | Load: 1.82 MPa | °C                   | 62                   |
| Coefficient of linear thermal expansion | ASTM D-696  |                | 10 <sup>-5</sup> /°C | 6.7                  |
| <b>Electrical</b>                       |             |                |                      |                      |
| Surface resistance                      | ASTM D-257  |                | Ohm                  | 4.1x10 <sup>14</sup> |

\* Please consult the web site for specific product specifications.

## PSDS Sheet

Download a detailed copy of the PSDS (Product Safety Data Sheet, used in place of MSDS Sheet) for PALBOARD Here.

In as much as Palram Industries has no control over the use to which others may put the material, it does not guarantee that the same results as those described herein will be obtained. Each user of the material should make his own tests to determine the material's suitability for his own particular use. Statements concerning possible or suggested uses of the materials described herein are not to be construed as constituting a license under any Palram Industries patent covering such use or as recommendations for use of such materials in the infringement of any patent. Palram Industries or its distributors cannot be held responsible for any losses incurred through incorrect installation of the material. In accordance with our company policy of continual product development you are advised to check with your local Palram Industries supplier to ensure that you have obtained the most up to date information.

© 2025 Palram industries Ltd. | PALBOARD is a registered trademark of Palram Industries Ltd.

Some Foam PVC products manufactured by others may contain lead.  
**PALBOARD® is manufactured without lead or any other heavy metal.**

